

CRESCENT 72 Series

Fusion Consoles™

The Shape of Things to Come

Made in America

Meet the FUSION CRESCENT™ 7224 Series.

Our small to mid room choice.
A separate height-adjustable monitor bridge on heavy duty casters and an independant desk give you the flexibility you want in a smaller room.



**As shown Model # CRESYS-7224 includes:
Desk, Monitor Bridge
& Under Counter Rack**

Distributed by

MARKETEC
a division of Rack Innovations Inc.

419 S. Flower St.
Burbank, CA 91502
800 557-8861 / 818 847-0200 Fax 888 262-1726
info@fusionconsoles.com
www.fusionconsoles.com



The Shape of Things to Come

Made in America

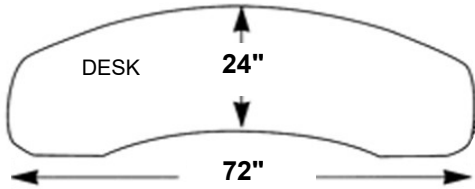
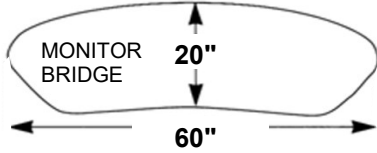

MONITOR BRIDGE

Model #CRESMB-6020-MHA

Manual Height Adjustability from 29" - 41"
on Heavy Duty Casters

Available with:

Tall Legs with Manual Height Adjustability (36" - 48")

DESK Model #CRESDSK-7224

Standard Desk Height with folding legs = 29"

Available with:

Casters

40" Tall Legs With or Without Casters

Manual Height Adjustability (29" - 42")

FOR OPTIONAL CONFIGURATIONS SEE PRICING CATALOG

SOLUTIONS....

Our popular Fusion Consoles™ series is recognized as the leader in the rental and post production community for its rugged durability and upscale design. Built with timeless style, our designs provide attractive, stable support which offer a comfortable space to work.

FUNCTIONALITY....

Interchangability. Designed to adapt, our separate pieces can be mixed and matched to meet your personal needs. **With the 2 position folding leg, all of our desks are designed to accommodate single or dual users.** Our consoles offer optional independent under counter racks that are built standard with front and rear rack rails. Our monitor bridges and desks are available in a variety of sizes to fit your equipment layout and work area. We can customize our existing styles to accommodate your needs.

Recommended Optional Under Counter Racks for our systems:

- UCR13RU24 13ru high x 24" deep with front and rear adjustable rack rails
- UCR13RU30 13ru high x 30" deep with front and rear adjustable rack rails (shown)

Racks available with Solid Bottom and (2) Adjustable Shelves in 24 or 30" Depths



The Standard Color for our Fusion Consoles™ is Phantom Grey Matrix. Customization of our Products and Colors are available. Just ask us!

ERGONOMICS....

Our independent monitor bridges are all height-adjustable on heavy-duty wheels, helping to eliminate back and neck strain. Our heavy-duty wheels make moving our furniture around secure and easy. Our curved design of the desks and monitor bridges pulls the equipment toward you, placing it within your line of sight and within reach.

AFFORDABILITY....

Lots of features at competitive pricing. From our under counter racks which ship completely assembled and ready-to-rack right out of the box to the simple and fast set up of our desks and monitor bridges. We save you time and money during assembly.

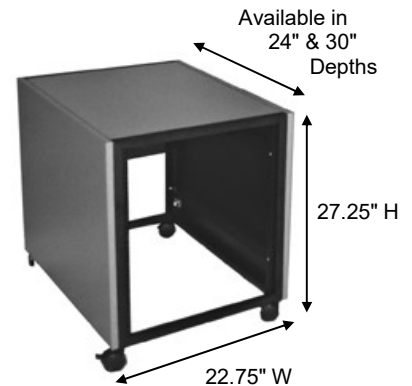

Distributed by MARKETEC, a division of Rack Innovations, Inc.
419 S. Flower St. Burbank, CA 91502 800 557-8861 / 818 847-0200 Fax 888 262-1726
info@fusionconsoles.com www.fusionconsoles.com